

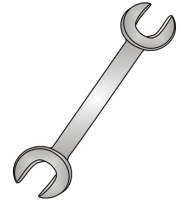

Tow-Trust Towbars

Important: Please read General Notes overleaf before fitting



Issue 5

TFD4 FORD C-MAX 2003> / GRAND C-MAX 2011> & FOCUS HATCH 2005> / FOCUS SAL 2005>

Item	Qty	Description	Item	Qty	Description
A	1	Crossmember	D	2	M16 x 50 Bolts Nuts & S/P Washers
B	2	Handed Side Arms	E	2	M12 x 85 Grade 10.9 Bolts & Nyloc Nuts
C	1	Extension bar	F	4	M12 x 40 Bolts, 2 Nuts & 4 S/P Washers
			G	4	M10 x 40 Bolts & S/P Washers
			H	4	10 x 40 Flat Washers
			J	4	12 x 25 Flat Washers

1. Remove the rear bumper. Two fixings along lower edge, two tip fixings each side, one fixing under wheel arch liner each side, four fixings when the tailgate is open. Pull the bumper out sideways at each tip then pull rearwards.
2. **FOCUS 3 2011>** Cut under tray to suit Towbar. (under tray can be left off the vehicle and handed back to the customer)
3. **FOCUS 3 2011>** Cut the lower edge of the rear bumper. 60mm wide x 20mm deep
4. Remove bumper beam. (This is not refitted with the Towbar.)
5. Place Item B into the open ends of each chassis and using Item G with Item H loosely bolt through existing holes.
6. Cut plastic tab off from the centre of the plastic rear panel.
7. Using Item F bolt Item A to Item B.
8. Fully tighten all nuts and bolts and ensure the Towbar is rigid and secure.
9. Replace bumper.
10. Using Item E with Item J bolt Item C to Item A.
11. Using Item D bolt the ball bracket and wiring plate (not supplied in this kit) to the mounting plate.

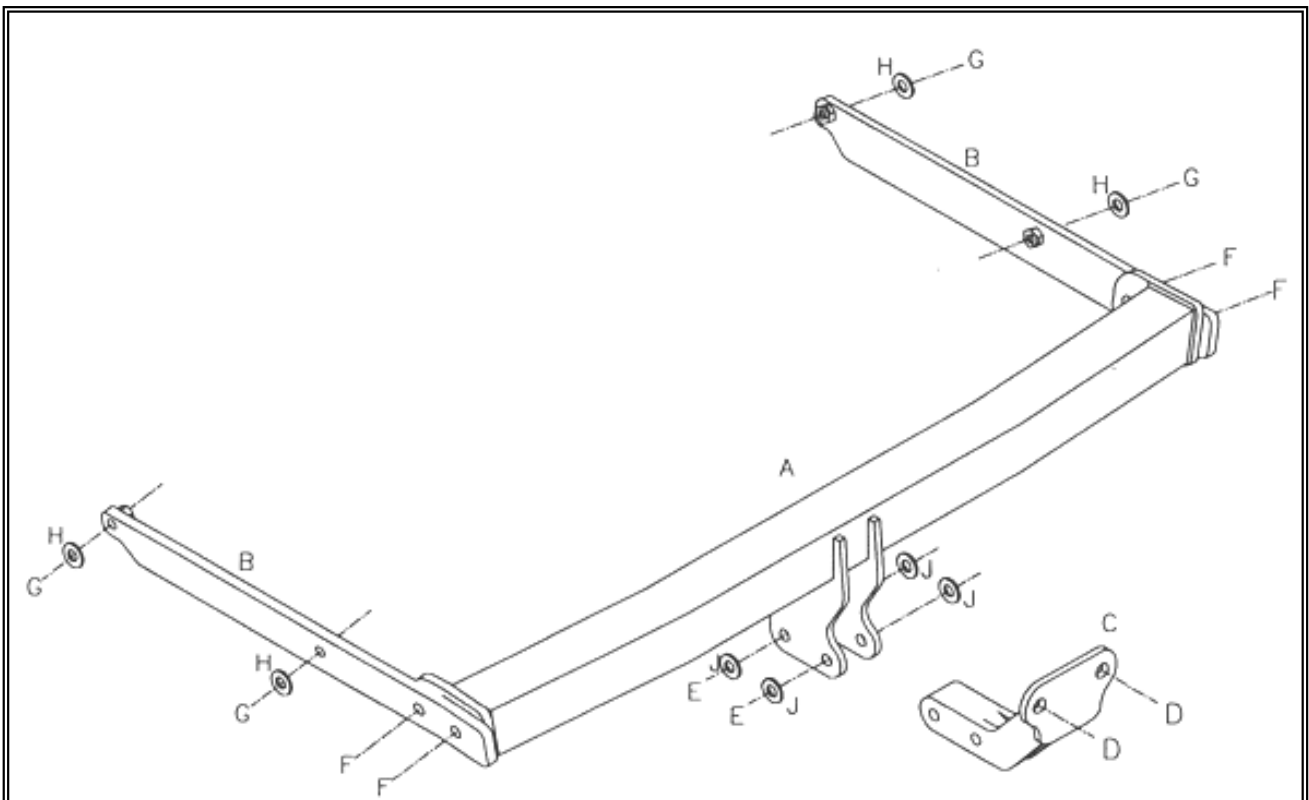

Note:

1. Recommended Torque Setting for M12 Grade 10.9 -139 Nm. (For other Torque Settings see notes overleaf.)
2. Nose load limits and vehicle manufacturers trailer / caravan weight limits must be observed.