



Tow-Trust Towbars

Important: Please read General Notes overleaf before fitting



Issue 1

TVOLV10SN V40 & V40 CROSS COUNTRY 2012>

Item	Qty	Description	Item	Qty	Description
A	1	TVOLV10 Crossmember	C	1	VASP8 L/H Socket Plate
B	1	ACS2 / 9202 Swan Neck	D	4	M12 x 40 Bolts & S/P Washers
			E	2	M12 x 110 Grade 10.9 Bolts & Nyloc Nuts
			F	2	15mm Spacer Plates
			G	4	12 x 30 Flat Washers
			H	4	12 x 25 Flat Washers

BUMPER REMOVAL:

1. Open the rear tail gate and remove the two rubber bumper stops. Remove two fixings along the lower edge of the bumper and five fixings in each wheel arch. Release the bumper from the vehicle body and pull rearwards. (Unplug any wiring looms)
2. Remove the rear impact beam (This is refitted over the Towbar assembly).

TOWBAR INSTALLATION:

1. Lower the rear exhaust silencer by removing the two fixings securing the hanger to the lower face of the chassis.
2. Insert Item A into the open ends of each chassis member and fix in place using Item D with Item G.
3. Using Item E with Item H and Item F fix Item B and Item C to Item A.
4. Fully tighten all fixings ensuring the Towbar is rigid, square and secure.
5. Refit the rear impact beam and rehang the exhaust silencer.
6. Cut the rear bumper as per the sketch below and refit. (On some models you may be required to trim the undertray or exhaust heat shield around the Towbars Central design).

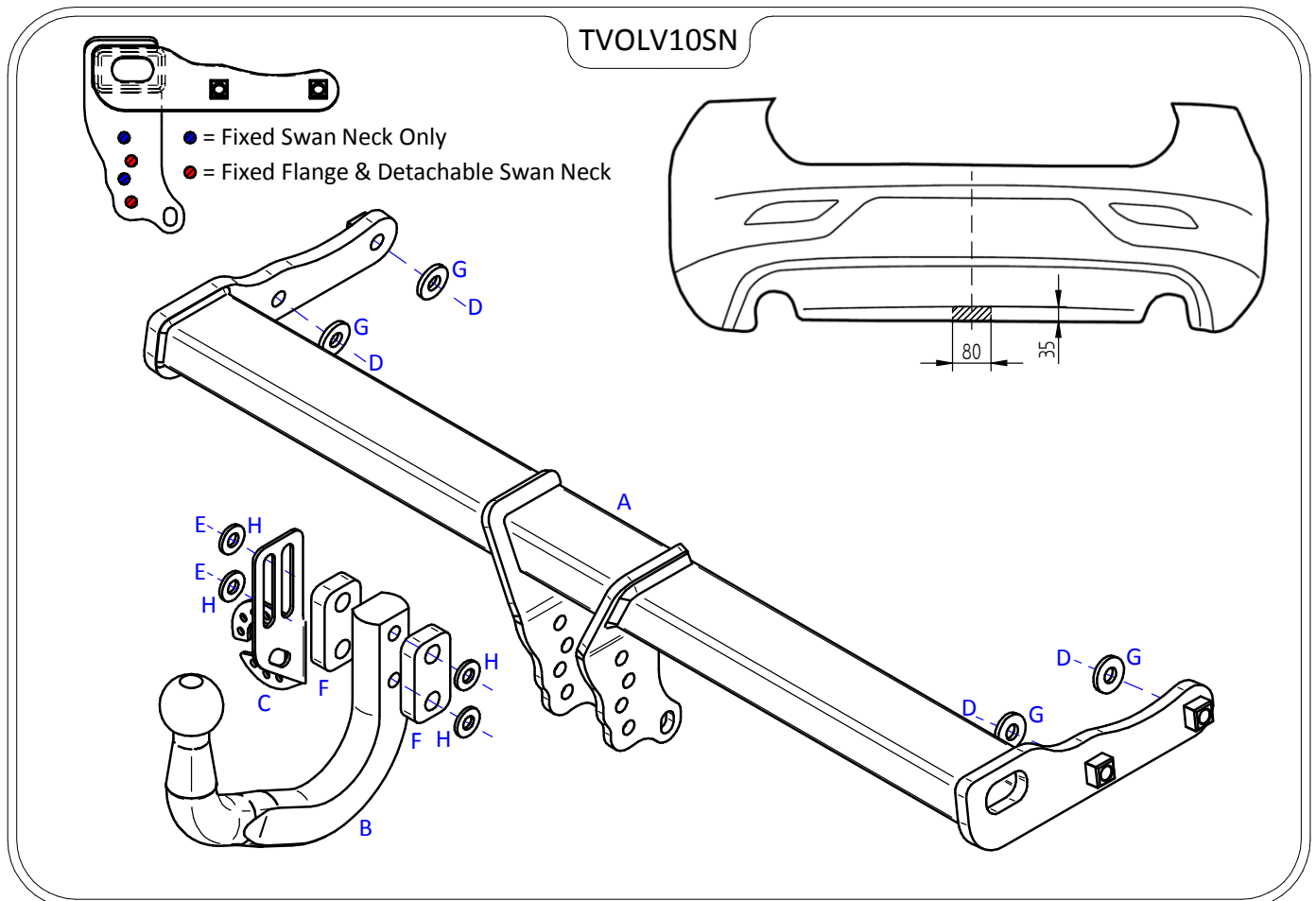

Note:

1. Recommended Torque Setting for M12 Grade 10.9 -139 Nm. (For other Torque Settings see notes overleaf.)
2. Nose load limits and vehicle manufacturers trailer / caravan weight limits must be observed.